

SKU	LARGE COIL SKU	POINT TYPE	LENGTH "L"	HEAD DIAMETER "ØH"	WIRE DIAMETER "ØD"	DEFORMED DIAMETER "ØS"
FC5DS086BD-PRM	---	BLUNT DIAMOND	1.75 [44.45]	.225 [5.72]	.086 [2.18]	.095 [2.41]
FC6DS086BD-PRM	---	BLUNT DIAMOND	2.00 [50.80]	.225 [5.72]	.086 [2.18]	.095 [2.41]
FC7DS086BD-PRM	---	BLUNT DIAMOND	2.25 [57.15]	.225 [5.72]	.086 [2.18]	.095 [2.41]
FC4DS099BC-PRM	---	BLUNT CHISEL	1.50 [38.10]	.255 [6.48]	.097 [2.46]	.110 [2.79]
FC5DS099BD-PRM	---	BLUNT DIAMOND	1.75 [44.45]	.255 [6.48]	.097 [2.46]	.110 [2.79]
FC5DS099BC-PRM	ACL5DS099BCPRM	BLUNT CHISEL	1.75 [44.45]	.255 [6.48]	.097 [2.46]	.110 [2.79]
FC6DS099BD-PRM	ACL6DS099BDPRM	BLUNT DIAMOND	2.00 [50.80]	.255 [6.48]	.097 [2.46]	.110 [2.79]
FC6DS099BC-PRM	ACL6DS099BCPRM	BLUNT CHISEL	2.00 [50.80]	.255 [6.48]	.097 [2.46]	.110 [2.79]
FC7DS099BD-PRM	ACL7DS099BDPRM	BLUNT DIAMOND	2.25 [57.15]	.255 [6.48]	.097 [2.46]	.110 [2.79]
FC7DS099BC-PRM	ACL7DS099BCPRM	BLUNT CHISEL	2.25 [57.15]	.255 [6.48]	.097 [2.46]	.110 [2.79]
FC8DS099BD-PRM	ACL8DS099BDPRM	BLUNT DIAMOND	2.50 [63.50]	.255 [6.48]	.097 [2.46]	.110 [2.79]

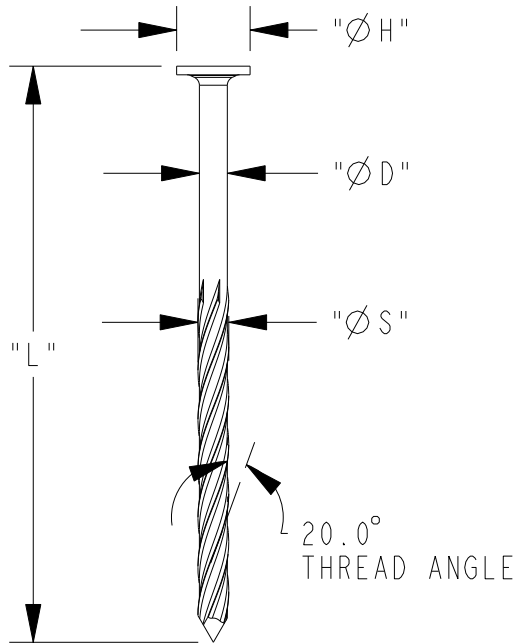

BLUNT CHISEL POINT

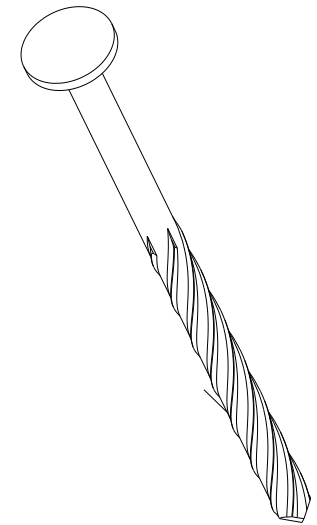
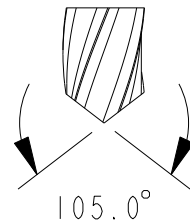

BLUNT DIAMOND POINT

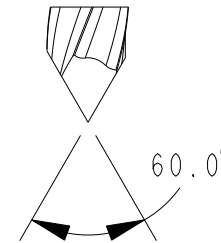

REV	DESCRIPTION	ECO NO.	REVISED/DATE	ENGR/DATE	MFG/DATE	METLGST/DATE
-	-	-	-	-	-	-
DIMENSIONS AND TOLERANCING IS IN ACCORDANCE WITH ANSI Y14.5M - 1982		THIRD ANGLE PROJECTION		DO NOT SCALE - WORK TO DRAWING OR MODEL DIMENSIONS ONLY ALL DIMENSIONS ARE IN INCHES (MM)		
DRAWN/DATE	MFG/DATE	PROPRIETARY AND CONFIDENTIAL NO PORTION OF THIS DRAWING MAY BE QUOTED OR REPRODUCED IN ANY FORM WITHOUT THE EXPRESS WRITTEN PERMISSION OF: STANLEY BOSTITCH				
RBW 10/3/12	.					
CHK'D/DATE	METLGST/DATE	DESCRIPTION PALLET PRM CUSTOMER DRAWING				
RBW 10/3/12	.					
ENGR/DATE	RELEASE ECO	PART NUMBER 182103				
RBW 10/3/12	60473					
SHEET NO.	SCALE	SHEET SIZE	REVISION			
1 of 1	1:1	A4	A			

- NOTES:
- FIVE (5) FLUTES
 - MATERIAL: LOW CARBON STEEL
BEND YIELD MINIMUM 100,000 PSI
 - WITHDRAWAL COATING ON SHANK
COATING ON HEAD IS PERMISSIBLE